

Square table 80 cod. JOSTQ080

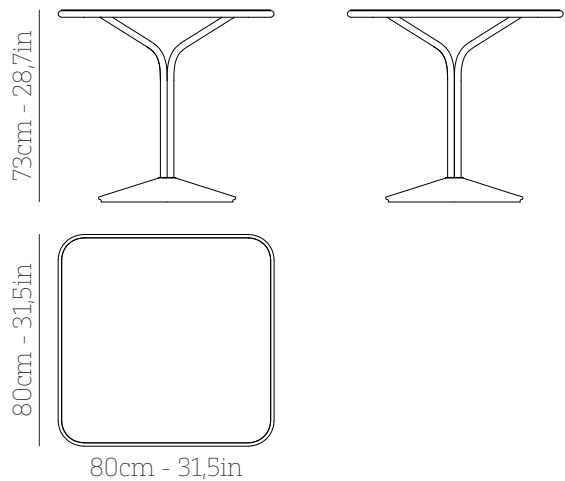

Steel frame
Top in steel or HPL

4 persons



Anticorrosive primer®

Application of a coat of protective anticorrosive epoxy resin-based paint.

Powder coating

60-80µm polyester powder coating for outdoor resistance and high protection.

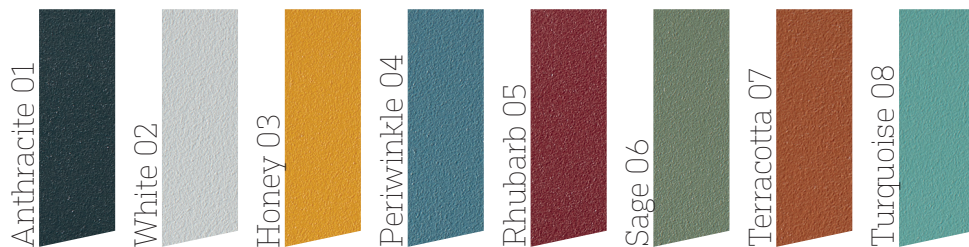

Steel maintenance

BABEL D products are treated to guarantee a long service life while preserving their functional and aesthetic qualities. BABEL D products will last longer if you take care of them by cleaning them with a soft cloth and water or neutral detergents every three to six months, depending on the

environmental and climatic conditions.

Do not use abrasive detergents and brushes. Be careful using BABEL D products in marine environments with high humidity or near swimming pools, especially in closed environments if chlorine is used as a disinfectant.

* 2D and 3D files are available at www.babel.it

Square table 80 cod. JOSTQ080

Top in HPL (High Pressure Laminate)

HPL consists of layers of paper impregnated with thermosetting resins and compacted with decorative paper and a protective coating. It is a self-supporting durable material suitable for outdoor use as it is resistant to weathering. Available in three different colours and textures (white, rust or concrete effect).

Maintenance

HPL tabletops can be washed with water and dried with a soft cloth. If necessary, use a sponge or a cleaner suitable for laminates and dry the surface with a cloth to avoid marks.

Do not use powders or abrasive cleaners.

 sp. 12mm

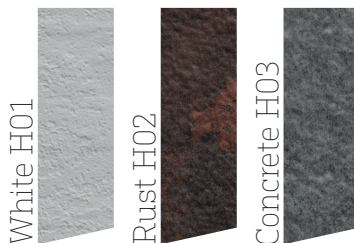



PROFESSIONALS

rypen
STUDIO

Register for Our Exclusive
Project Builder + Ordering Platform